

HORIZONTAL PIPE LIFTING CLAMP

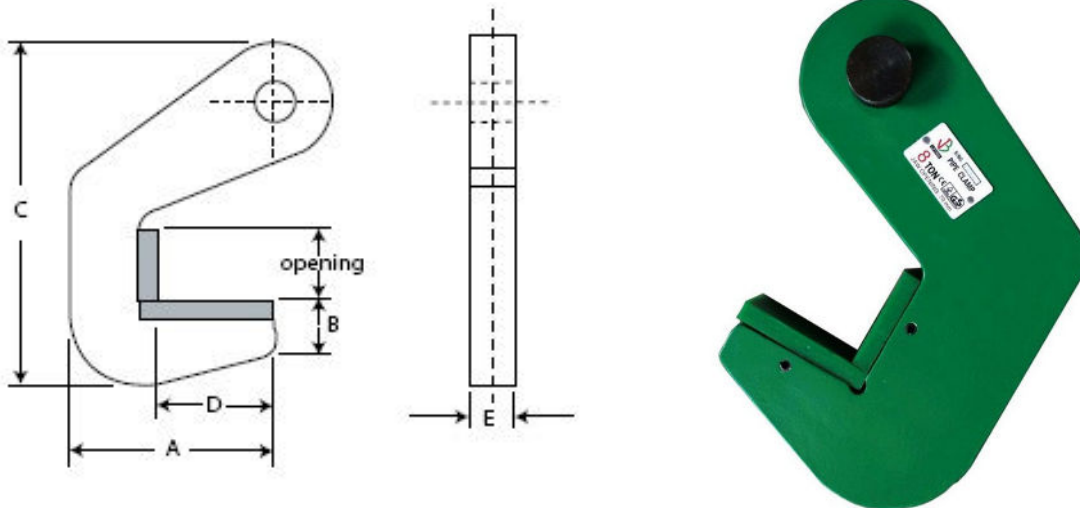

FEATURES

- For horizontal lifting and transportation of steel and concrete pipes.
- Compact shape and relatively low own weight with a high lifting capacity.
- The surface is equipped with Teflon.
- Teflon coated horizontal pipe lifting clamp
- These clamps must always be used in pairs
- Traceability code, CE, WLL marked on label plate.

HORIZONTAL PIPE LIFTING CLAMP

PHK

ItemCode(s)	Capacity per pair WLL	Jaw opening	Dimensions					Weight
			A	B	C	D	E	
	(Tons)	(mm)	(mm)	(mm)	(mm)	(mm)	(mm)	(kg/pc)
PHK-1.5T	1.5	40	120	32	195	75	35	2.2
PHK-03T	3.0	40	120	32	195	75	35	2.5
PHK-04T	4.0	50	120	32	205	75	40	3.0
PHK-06T	6.0	50	120	32	205	75	40	3.3
PHK-08T	8.0	70	120	32	205	75	40	4.5



WARNING

Never exceed Working Load Limit

The data of products dimension in the catalogue is just for reference!
Copyright©2023 | www.safeandsecureksa.com | All rights reserved